

# A NOVEL STUDY

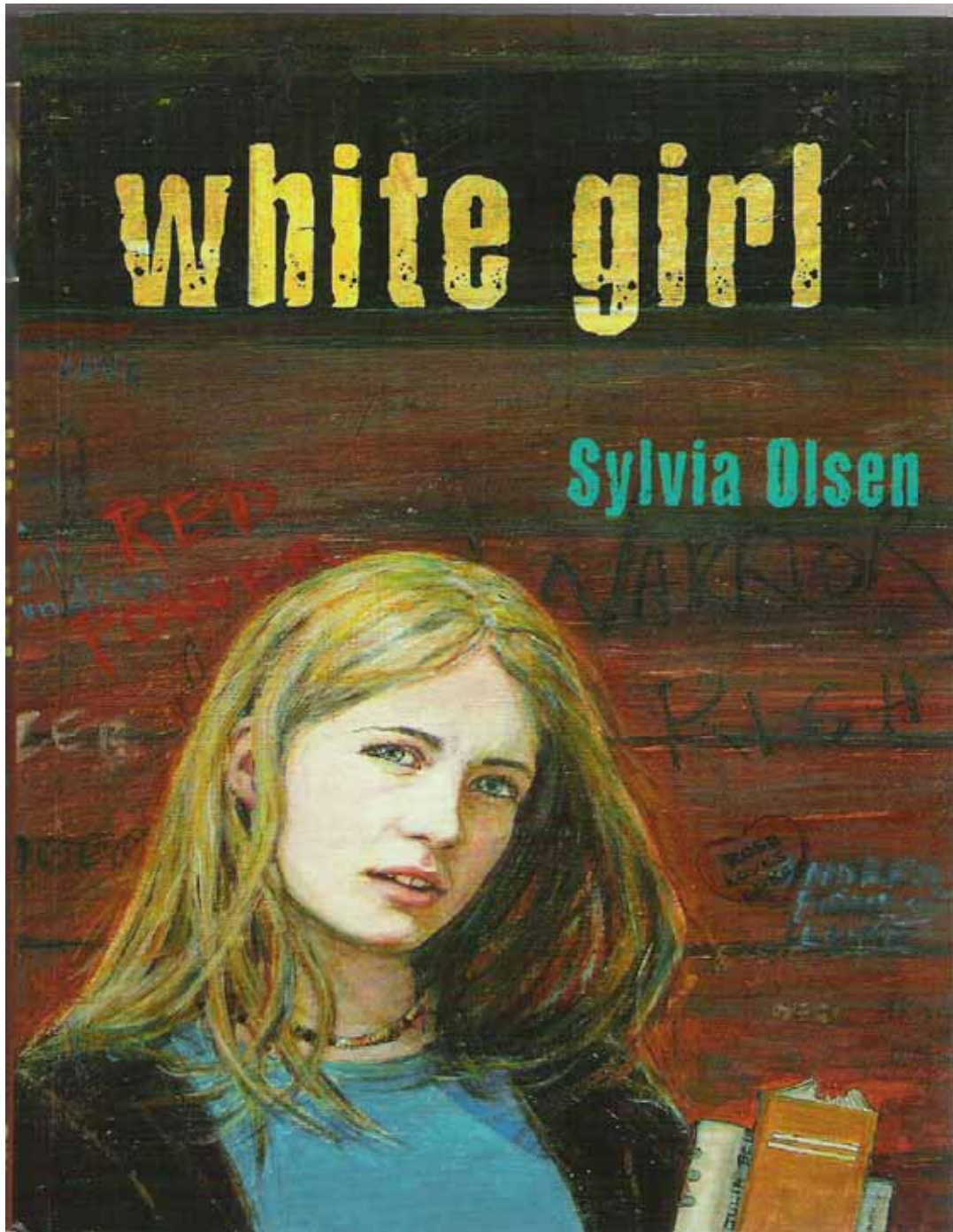

## **Novel Study Project**

This novel study project was developed by the Regional Vancouver Island Aboriginal Circle with the help of the Aboriginal Education Branch at the Ministry of Education.

Special thanks to Louise Spencer for her contributions.

The goal of the novel study project was to create lessons incorporating Aboriginal literature and/or Aboriginal authors, while keeping in mind, the Aboriginal learner.

In order to best meet these goals the lessons were designed to:

- Respect the cultures of Aboriginal and non-Aboriginal people who may read and participate in these lessons.
- To use a non-linear approach
- To provide mix and match strategies that may be applied to many texts
- To use graphic organizers whenever possible to accommodate the inclusion of a diversity of learners
- To provide opportunities to integrate English and Social Studies
- To include elements of writing, inquiry, collaboration and reading in each lesson
- To provide a set of questions that can be used as prompts for discussion groups, journaling activities, comprehension or evaluation

# white girl

A Novel By: Sylvia Olsen

ISBN:1-55039-147-X

## NOVEL SUMMARY

White girl is about a 14 year old girl whose mom marries an aboriginal man. They move to the reservation to live with him and his son. It deals with racism head on in a real way. It is set in modern times and points out cultural and philosophical differences on and off of the reserve. The writer's cultural attitude feels totally unbiased. She makes the reader see that amongst the differences, we are no different. It's modern setting and real life issues will likely appeal to teens.

*\*Winner of BC Book Prize*

## ABOUT THE AUTHOR

Sylvia Olsen was born and raised in Victoria. When she was seventeen, she married a member of the Tsartlip First Nations. Olsen has raised her four children within the Tsartlip community.

Olsen obtained a Master's degree in History. She now works in first nations community management. She is conducting research with teen parents from the Saanich First Nation, to increase the community's support network for young parents.

### Issues and Themes:

- race relations
- bullying and friendship
- teen group dynamics
- parenting and role models
- importance of elders
- perspective
- sexual feelings
- power of family

\*Also by this author: "[Girl With a Baby](#)"

**RECOMMENDED GRADE LEVEL: 8-9**

white girl

**STUDENT ACTIVITY 1: Creating a Learning Journey**

**Objective:** To pinpoint moments in the story where a character's learning takes place. Display the icons on an overhead. Each student receives a copy to cut and paste to either a poster or a book, and an additional copy to make notes on.

- 1 Describe/talk about the learning journey of a character that is familiar to the class. Go over examples provided from White Girl to **demonstrate** how to use quotes to pinpoint a character's learning journey.
- 2 Break into groups. Each group receives one icon. (All the same one, or all different. For easier review, have all the class work on the same icon.) Have students brainstorm words that describe the various icons.
- 3 If a group has the "gas pump" icon, they look for quotes that show where these 'fulfilling moments' occur.
- 4 Rotate through the icons to different groups, one per day is probably enough. Maybe two if you have long classes. Depending on the group, and their ability to scan text for evidence, do each icon one at a time in group situations or assign as a project.
- 5 Each student creates a learning journey for Josie, either on a poster or book style. (One icon per page). Fold 11x17 paper in half for books or use large rolled paper for posters. ( Books are easier to transport in binders.)

white girl

STUDENT ACTIVITY 1: Creating a Learning Journey

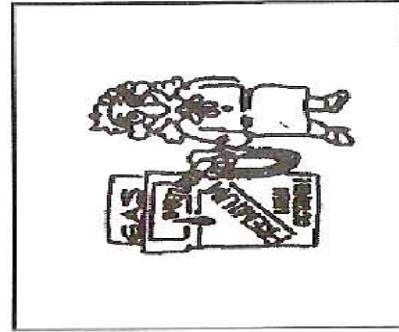
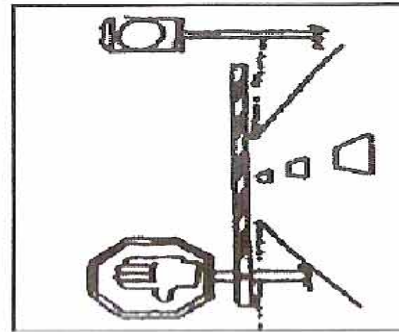
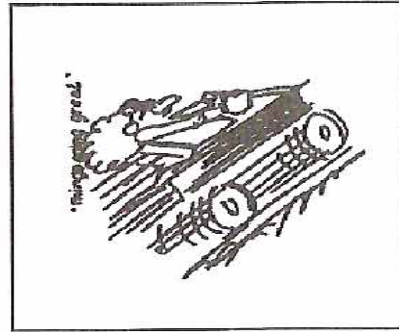
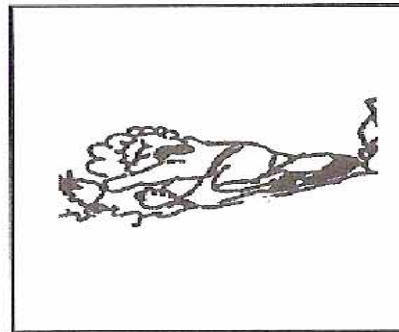
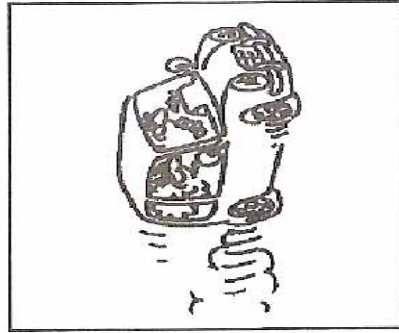
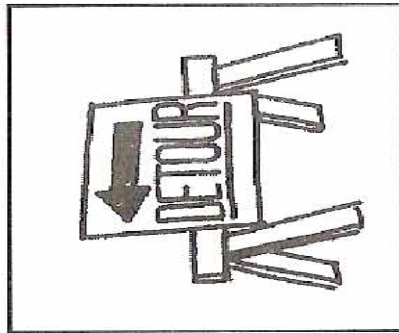



## STUDENT ACTIVITY 1: Creating a Learning Journey

### What does this icon represent?

This icon stands for those moments when the character is: filled up, refreshed, filled with hope, happy, joyous, rewarded (students brainstorm in their groups for what each icon represents, including all ideas of the group.)

### Example 1:

#### What happened?

One refreshing moment for Josie was when she has a bonding conversation with her new step-brother, Luke.

#### Quote:

“We were having an everyday conversation, I was talking, he was talking. I couldn’t get a grip on it - it had been so long since I was a person.” (page 30)

### Example 2:

#### What happened?

Josie is thinking about how quickly things can change. How things can suddenly ‘gel’.

**Quote:** “That night I lay in bed, thinking about the day. A week that had started on the brink of disaster had ended with the best day of my life. Rose was my friend- the ocean between us was shrinking. I pulled my head into the blankets and closed my eyes.”( page 145)

**What happened?**

**Quote:**

**What happened?**

**Quote:**

**What happened?**

**Quote:**

**What happened?**

**Quote:**

white girl

**STUDENT ACTIVITY 2: Visualizing While You Read**

**Objective: Use illustrations to retell a story by visualizing what is heard.**

- 1 Divide paper into **6 or 9 squares** by folding.
- 2 **Read** aloud chapter 3 while students listen and draw. They can draw what they like as long as it helps them to recall the story.
- 3 This chapter describes Josie's first impression of the reserve and Rose's impressions through her accustomed eyes.
- 4 In groups, show pictures and **recount** individual responses of what they visualized.
- 5 Groups **scan** chapter 3 to find words that helped them to 'see the setting'. **Copy** these words onto the back of your square sheet.
- 6 **Read** your quotes to a partner in another group and see if they can **choose** the picture which you drew to match the words you heard.



# Nine Squares

**STUDENT ACTIVITY 2: Visualizing While You Read**  
**Storyboard for:**

---

white girl

**STUDENT ACTIVITY 3: Gallery Walk**

Read chapter 12- page 175-176 (introduction)

Do a **gallery walk** around the questions on the posters. **State** whether you agree or disagree on a scale of 1-5 on each poster hung up around the room.

1  
strongly disagree

2

3

4

5

strongly agree

Gallery Topics

- ◆ All people are created equal.
- ◆ New immigrants to Canada should have to have a background check.
- ◆ New immigrants to Canada should be able to speak English, French or an Aboriginal language of Canada.
- ◆ Reservations should be made bigger.
- ◆ Learning about different cultures is good for you.
- ◆ Your family's culture is important to maintain.
- ◆ Europeans should be ashamed of what they did to the Aboriginal People of Canada in history.
- ◆ Skin, hair and eye colour is what determines your cultural label.
- ◆ Parents shouldn't be worried if their children marry outside of their culture.
- ◆ "All is fair in love and war."

white girl

**STUDENT ACTIVITY 3: Gallery Walk**

- 1 Decide whether or not you agree or disagree. Write either yes, no or partly on the chart.
- 2 Discuss the responses in large group. Ask people to justify their answers orally.
- 3 In small groups choose one chart.
- 4 Transfer your quote to the “Viewpoint” page.
- 5 Decide individually whether or not you agree or disagree on a scale of 1-5.
- 6 Discuss and write your group’s thoughts on the “Viewpoint” page.
- 7 Individual response: Write about your thinking and whether or not your viewpoint changed after you heard others’ points of view.

Think about these questions:

- ◆ Can your thinking change after discussions?
- ◆ Did it change?
- ◆ Did you stay strongly opinionated on any topic in particular?
- ◆ Do people’s experiences influence their beliefs?
- ◆ Do parents influence their children’s beliefs?

**Group Discussion Notes:**

# VIEWPOINT

Name: \_\_\_\_\_

Activity: \_\_\_\_\_

## STATEMENT:

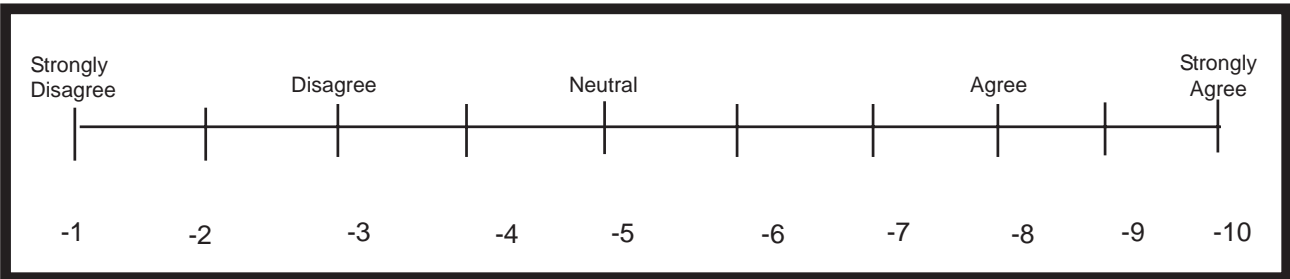

## PERSONAL FEELINGS OR REASONS:

## GROUP STATEMENT:

## RESPONSE TO GROUP PRESENTATIONS:

white girl

**STUDENT ACTIVITY 3: Gallery Walk**

**Writing an Essay**

Choose a topic from one of the gallery walks or four corners activities.

Use the graphic organizer to sort out your thoughts. Write your thesis statement and then think of points to help you write persuasively. Try to help the reader to understand your point of view.

- ◆ Remember that essays are like telling someone what you think of the topic.
- ◆ Using quotes from other people can only help to support your opinion.
- ◆ Make your topic into a statement that suits you. For example:

**Racism is alive and well in Canada**

**Could be changed to:**

**Canadians are working hard to eliminate racism**

## white girl

### STUDENT ACTIVITY 4: Similes and Metaphors

**Objective:** To be able to define and locate similes and metaphors in text and practice writing your own.

#### Opening Activity:

**What do these words really mean?**

**I am an island.**

**I am a rock.**

**This is like climbing a mountain**

In groups, discuss and fill in the missing words to these similes and metaphors taken from White girl. Your word choices are given below.

- 1) "It was better than the dry, sugar-coated cereal I used to eat at home, which tasted like \_\_\_\_\_ and cotton candy." (page 24)
- 2) "I filled my spoon with oatmeal and watched the porridge until I opened my mouth. If I didn't think about what it looked like- \_\_\_\_\_ - mush with brown sugar and milk it didn't taste so bad." ( page 24)
- 3) "She would start a sentence and then, in order to avoid making a decision about how to end it, she would leave the last word hanging like \_\_\_\_\_ . (page 47)
- 4) "...watched Grandma move her wheelchair across the room and back, refilling our cups with tea and our plates with cake. She was in charge, moving from one the other, conducting her party like \_\_\_\_\_." (page 84)
- 5) "Her voice got shriller as her self-control ebbed away. She looked like \_\_\_\_\_ . (page 87)
- 6) "My eyes were baby blue most of the time. When I stared into the mirror they reflected light like \_\_\_\_\_ . "(page 8)

...a bat on a tree

...a maestro

...Styrofoam

...wet concrete

...a frozen branch, ready to crack

...like pools of water

...pools of water

## white girl

### STUDENT ACTIVITY 5: Writing your own Metaphors

In groups or on your own, **write** similes or metaphors for the following sentences to make them interesting sentences. (Remember that they must compare one thing to something else.)

*Josie was so mad.*

*The house was small.*

*Josie's mom was acting in an immature way.*

*Luke is tough.*

*Zeb is cool.*

*Grandma was fast in her wheelchair.*

*The reserve was unfamiliar to her.*

white girl

**STUDENT ACTIVITY 6: Characters and Relationships**

Keeping Characters straight

Join the characters with arrows. On the lines, explain their connections and relationships.

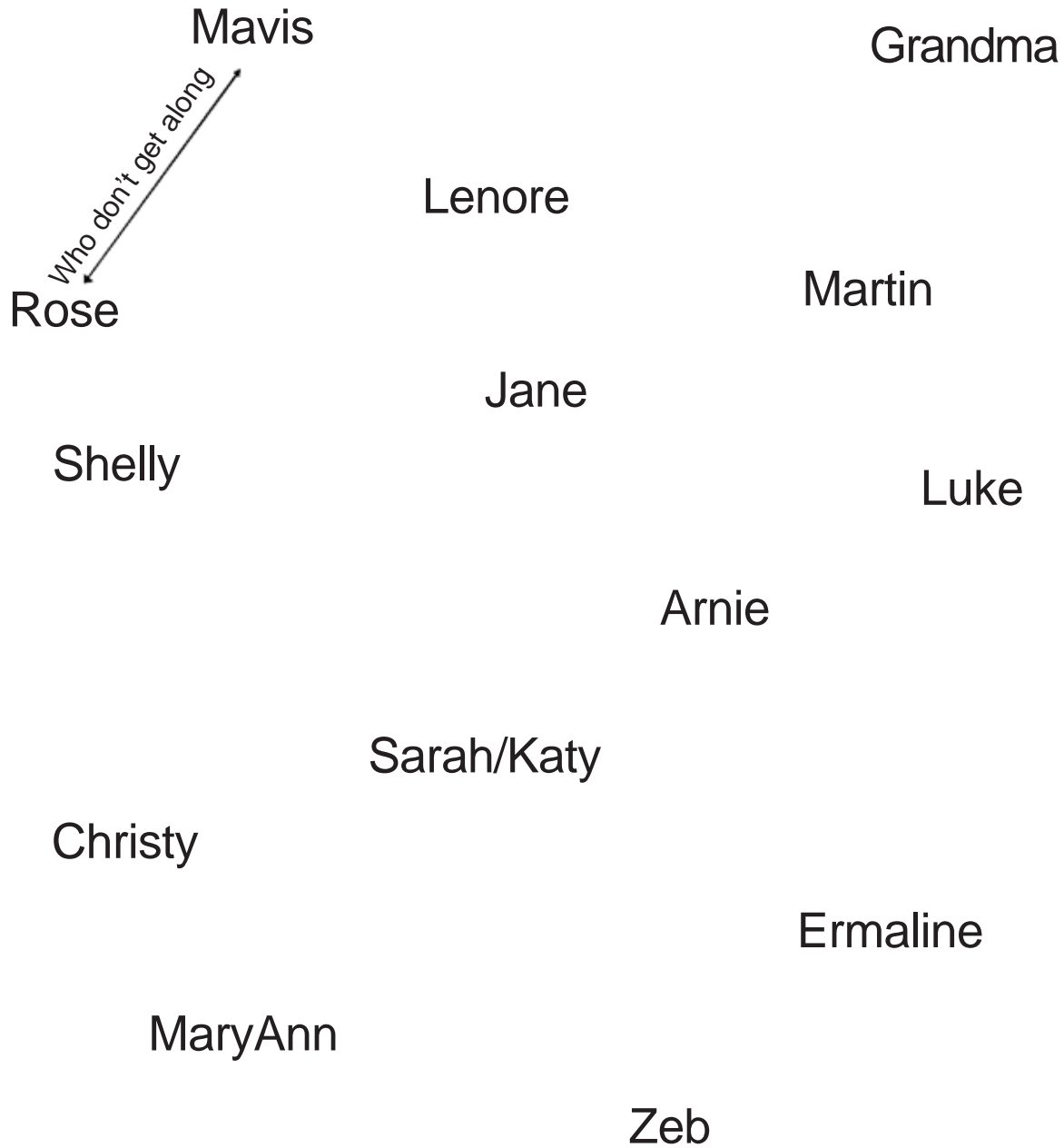



## white girl

### STUDENT ACTIVITY 7: Conflict

**Objective:** To identify character conflict and character thoughts about their conflicts as well as provide possible solutions to those conflicts.

Begin lesson by filling in a **story map** on the overhead as students give information that they recall. Explain that they will need this information to refer to when they show Josie's learning journey later in the novel. Remember that the learning journey will represent Josie's conflicts and how they were resolved. Model conflict from another story using the conflict chart.

**Students:**

Read, think about and notice conflicts or problems the characters are having. Use post-it notes. Be sure to look for internal and external conflicts. (Where they war with themselves and others.)

Complete conflict chart in groups.

## Conflict Chart

Characters Thoughts

Characters Thoughts

**Conflicts**  
**Internal and External**

*Josie worries about the fact that she stands out because she is blonde.*

*She doesn't like people calling her Blondie because it makes her different.*

○ **Josie looks very white.**



**Solutions**



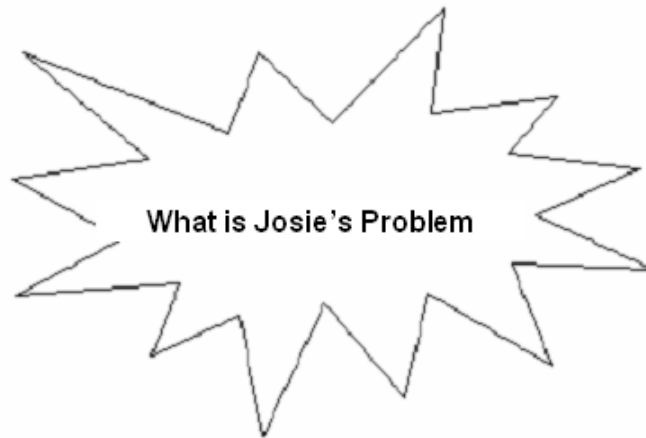

Problem

Solution 1

Solution 2

Solution 3

Consequences:

- 
- 
- 

Consequences:

- 
- 
- 
- 

Consequences:

- 
- 
- 
- 

What should Josie do?  
Recommendation of the group: